



CONTAINER OPERATION



SB151 OPERATION AND SERVICE

Table of Contents

Safety Summary.....	4
Preparation	5
Preparing your Site for the Refrigerated Container	5
Electrical Connection.....	6
Electrical requirement:.....	6
Voltage:.....	6
Initial Start	9
Initial Start-up:.....	9
Control Panel:.....	9
NOTE: The light bulbs are 230 volts and can be purchased from:.....	12
Main power circuit breaker:.....	12
Interior lights and timer switch:.....	12
Thermometer.....	12
USE.....	13
Loading your product:.....	13
Defrost:	13
The Condenser coil.....	13
Support.....	14
Refrigeration Unit SB151	14
MODULAR CONCEPT.....	14
FEATURES OF THE SB151 MODULAR UNIT.....	14
COMPONENTS	16
Technical Data Technical Data Sheet.....	17
Controller – Parameters	18
Location of major components in the modular unit:.....	19
Defrost sequence:.....	19
Refrigerant:.....	19
Specifications:.....	Error! Bookmark not defined.
Maintenance:.....	22
Monthly:.....	22
Seasonal operation:.....	22



Clean all coils.....	22
Troubleshooting Guide	23
Diagrams.....	30
Electrical Diagrams.....	35
Domestic Reefers Series	38

Table of Figures

Figure 1 Transformer Terminal Strip Pre-Wired	7
Figure 2 Component Identification.....	10

Safety Summary



This warning summary contains general safety warnings and hazardous materials warnings that must be understood and applied during operation and maintenance of this equipment. Failure to observe these precautions could result in serious injury or death to personnel. Also included are explanations of safety and hazardous materials icons used within the technical manual.

EXPLANATION OF SAFETY WARNING ICONS



BIOLOGICAL - abstract symbol bug shows that a material may contain bacteria or viruses that present a danger to life or health.



ELECTRICAL - electrical wire to arm with electricity symbol running through human body shows that shock hazard is present.



EXPLOSION - rapidly expanding symbol shows that the material may explode if subjected to high temperatures, sources of ignition or high pressure.



FIRE - flame shows that a material may ignite and cause burns.



FLYING PARTICLES - arrows bouncing off face with face shield shows that particles flying through the air will harm face.



HEAVY OBJECT - human figure stooping over heavy object shows physical injury potential from improper lifting technique.



HOT AREA - hand over object radiating heat shows that part is hot and can burn.



VAPOR - human figure in a cloud shows that material vapors present a danger to life or health



Preparation

Information about the Placement and Operation of the *20' Cold Storage 2 Go* Domestic Refrigeration Unit

Preparing your Site for the Refrigerated Container

- 1) The surface where the container is to be placed must be stable enough to support the weight of the container (6,900 lbs.). Concrete, asphalt, gravel and crushed concrete all work well. The bearing weight of the container is at the corners.
- 2) A reasonably level area is desirable. Wooden blocks or railroad ties may be used to level the container.
- 3) Make sure there is sufficient access for the delivery truck.
- 4) Have your electrician check that you have the **proper** electrical supply available near to where your container will be located.
- 5) Position the machine end of the container no closer than 5 feet from a wall or other object that may block airflow or limit access.
- 6) The container should be perfectly level from side to side to allow the evaporator defrost drains to work properly. There should be a slight pitch toward the doors which will allow any water to drain particularly when

washing out the container.

Electrical Connection

Electrical requirement:

240 volt / Single Phase / 30 Amps

(Note: The interior light bulbs are 240 volts)



Voltage:

It is important to operate the unit at the correct voltage. This unit is equipped with both a booster transformer located just below the refrigeration unit and a voltage monitor located on the circuit breaker box. No less than 220 volts is recommended when the compressor is operating. The booster transformer comes pre-wired using the 208 terminal.

- 1) FIRST, TURN OFF THE MAIN BREAKER FROM THE BUILDING TO THE CONTAINER.**
- 2) ATTACH THE WIRES TO THE LOCAL POWER SOURCE ACCORDING TO LOCAL ELECTRICAL CODES**
- 3) MAKE SURE THAT THE MAIN BREAKER TO THE REFRIGERATION UNIT IS OFF**
- 4) ENERGIZE THE LOCAL SOURCE**
- 5) READ THE VOLTAGE MONITOR FOR INCOMING POWER LEVEL**
- 6) IF THE LEVEL IS BELOW 230 VAC DO THE FOLLOWING**

If the voltage is low, an adjustment can be made at the booster transformer. This should be done by a qualified and authorized person.

Open the hinged cover on the transformer. Measure with a volt meter, set to read AC volts on the 600 volt scale, between the 0 lug on the transformer wire and the other terminals. Note which terminal is at 230 volts. **TURN OFF POWER AT THE SOURCE**



Move the wire that goes to the refrigeration unit from the 208 terminal to the terminal that measured closest to or at 230 VAC. REMEMBER to tighten the nuts on the terminal to secure.

As a precaution check that all nuts are tight and secure. Loose connections can cause a variety of problems that at first may not seem power related.

Figure 1 Transformer Terminal Strip Pre-Wired

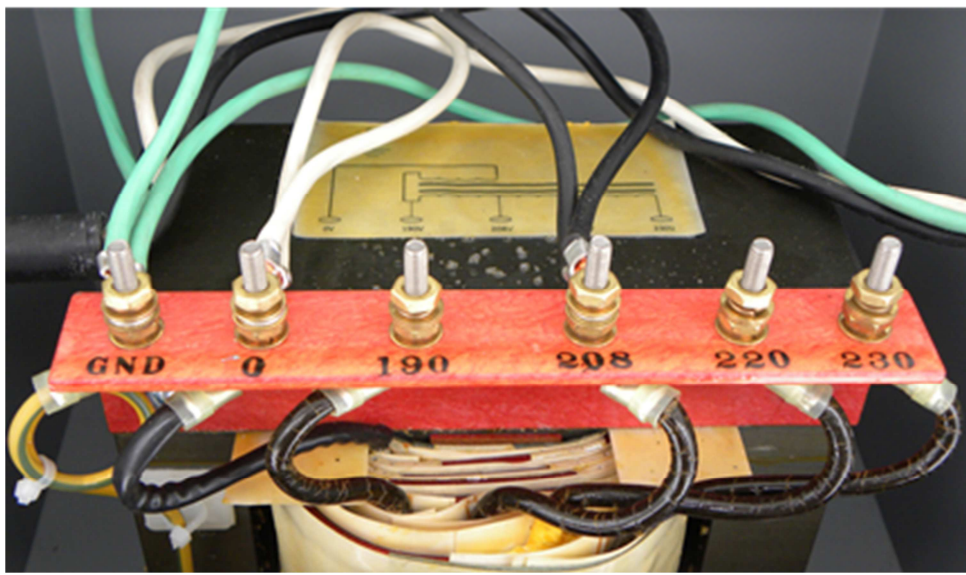

Reference page 32 for further details



Secure the cover and turn on the main breaker. Recheck the voltage and, if necessary adjust by moving the wire to a higher or lower terminal that will supply the correct voltage.



Initial Start

Initial Start-up:

After connecting the electrical power, it is advisable to wait several hours (especially in cold weather) before starting the unit.

If a grinding noise is heard, shut off the unit and allow more time for the heater to work. Only after allowing the heater to run, briefly turn the unit on and off to assist in the start-up.

Control Panel:

Reference Figure 2 for location

The control panel is located on the left side of the refrigeration unit at the front of the container.

- 1) Unit on / off switch: Located on the outside of the control box door.
- 2) Electronic Controller: Located on the outside of the control box door, the controller includes a temperature display, temperature set point adjustment and manual defrost button. (see diagram, page) Reference page 11 for illustration.

The electrical panel contains high voltage, Caution should be used when accessing the panel.

The panel door must be kept tightly closed at all times.

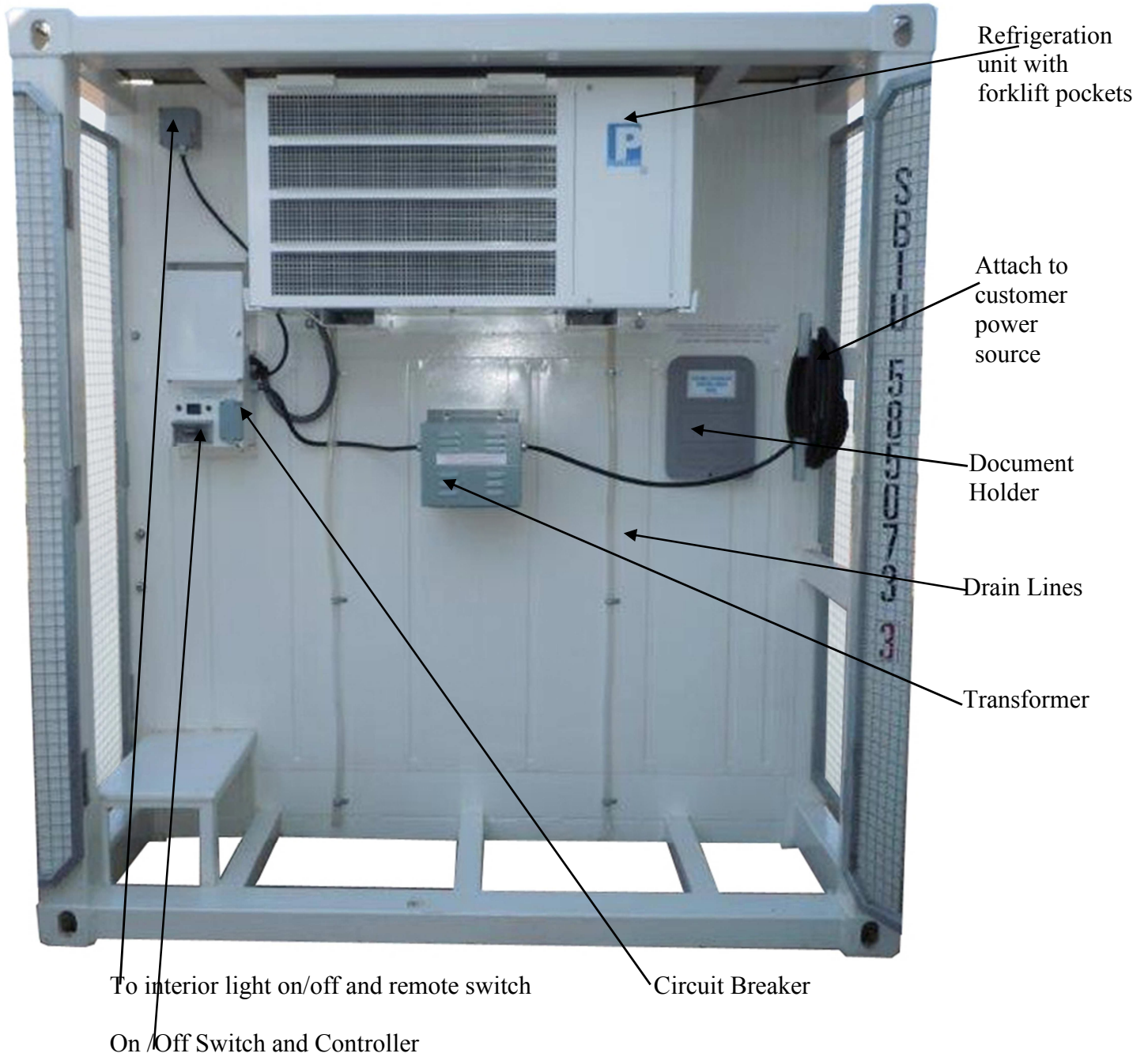

Figure 2 Component Identification

DIXELL CONTROLLER FRONT PANEL COMMANDS

IMPORTANT - SELECT FREEZER OR COOLER POSITION
SET CONTROLLER TO DESIRED TEMPERATURE
(HOLD SET BUTTON UNTIL LIGHT FLASHES, USE ARROW TO ADJUST TEMPERATURE, PRESS SET BUTTON)
-10° F TO +14° F / +15° F TO +50° F
FREEZER  **COOLER**



SELECT:

FREEZER OR COOLER POSITION

SET:

TEMPERATURE

HOLD BUTTON UNTIL DISPLAY FLASHES – PRESS ARROWS UNTIL DESIRED TEMPERATURE APPEARS – PRESS SET



INCREASE THE DISPLAY VALUE

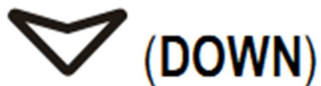

DECREASE THE DISPLAY VALUE



START MANUAL DEFROST



NOTE: The light bulbs are 230 volts and can be purchased from:

: <https://www.interlight.biz/light-bulb/60A-220-240V-TUFF>
info.php/products id/238

Main power circuit breaker:

Located on the front wall of the container below the refrigeration unit.

AUTHORIZED PERSONNEL ONLY

Interior lights and timer switch:

Located on the right side wall, just inside the main door. The timer switch is designed to turn the refrigeration unit off when access to the container is needed and automatically turns the unit on after the pre-set time has expired. The timer can be set for up to 15 minutes or the unit can be turned on manually by returning the timer back to the on position.

* ALWAYS TURN THE UNIT OFF WHEN THE DOORS ARE OPEN TO AVOID
TEMPERATURE LOSS OR SEVERE ICING OF THE EVAPORATOR COIL.

Initiating a manual defrost once or twice daily will prevent ice from accumulating on the evaporator coil.

Thermometer:



The thermometer located on the rear door should ONLY be used as a temperature indicator once the unit has been operating with the doors closed for several hours.

USE

Loading your product:

The product should be loosely loaded allowing maximum airflow to surround your product. Do not block the airflow from the evaporator section. The supply air must be able to reach the door end of the container.

Defrost:

This controller is programmed to defrost the evaporator coil every six (6) hours. If ice accumulates on the evaporator coil, the defrost cycle can be initiated manually by pressing the defrost button on the controller. It is expected that during every defrost cycle, water will drain from the two (2) hoses located on the front wall of the container. These hoses must be kept clear of ice, snow and debris at all times.

The Condenser coil:

This is the aluminum grill on the outside front of the refrigeration unit that needs to be kept clean. When dust and dirt builds up on the coil the unit will not cool properly. To clean the coil, first shut off the electrical power at the breaker on the container as well as the breaker in your building. Using a garden hose with a spray nozzle, GENTLY spray the coil to wash out the dirt. Using too much pressure will bend the aluminum fins and damage the unit. The water will not harm the refrigeration unit. Keep spraying until the water flowing from the coil is clean. Allow to dry for 20 minutes before starting.

Before closing the container doors, ALWAYS check that no one is inside the container.

Support:

Email: Reeferrepairs@seabox.com

Include your company name, location, contact information, and briefly describe the support required.

Refrigeration Unit SB151



MODULAR CONCEPT

The modular concept is a new design that enables the use of a single unit to satisfy the refrigeration load requirement. Every unit is pre-built at the plant and is equipped with a compressor, condenser and evaporator. Each unit is pre wired and pre-charged by qualified technicians. These units offer many advantages compared to conventional split units.

FEATURES OF THE SB151 MODULAR UNIT

- 1) Quality control monitoring takes place throughout the fabrication process and three (3) leak tests are done. One each on the: condenser coil, evaporator coil, and piping system. A thorough operational test is performed on the unit to make sure it performs efficiently.
- 2) The quantity of refrigerant necessary is 10 lbs. compared with 14-16 lbs. on conventional units of the same capacity. This means that the cost associated with recharging and leak repair is reduced.
- 3) The number of solder joints is minimized, thus reducing the risk of a leak.
- 4) With easy access the inspection and maintenance is relatively easy.



- 5) The unit can be removed and replaced easily.
- 6) Because of the low cost, an extra or spare unit can be kept on standby.

- 7) Spare parts such as relays, driers, compressors, and valves, etc. are standard and readily available in the refrigeration industry.
- 8) The drain system is located within the unit, thus eliminating a complex and costly drain system.
- 9) The final electric wiring is simple to connect because the pre-wiring is done at the factory.
- 10) With short connections between components, the control of the oil migration is better therefore the chance of mechanical failure of the compressor is reduced.
- 11) Simple to install, even in the most remote areas, without the support of a technical refrigeration mechanic.



COMPONENTS

Compressor: The SB151 is equipped with a scroll compressor with internal thermal protection. The table on page 18 shows the compressor specifications.

Condenser: The coil is manufactured of 3/8 inch copper tubing with 12 aluminum fins per inch.

Evaporator: The coil is manufactured of 3/8 inch copper tubing with 8 aluminum fins per inch.

Fans: Both the condenser and the evaporator use one (1) fan to circulate the air. Each fan is powered by one (1) 1/3 HP electric motor on the evaporator side and one (1) 1/3 HP electric motor on the condenser side. Reference the Table on page 20.

Controls: There are 3 PENN electro-mechanical controls consisting of low pressure and high pressure safeties and condenser fan cycling and 2 DIXELL electronic controls consisting of a dual map combination temperature and defrost controller and a separate superheat controller.

Electric Heat: 3 KW heat strips provide product protection at low ambient temperatures.

Defrost: Hot gas defrost.

Accessories: Drier, liquid glass indicator, electronic expansion valve, evaporator pressure regulator, and liquid receiver.

Casing: The condenser casing is made out of satin finished steel that is cold bended and covered with primer and paint. The evaporator casing is made out of aluminum. The evaporator and condenser sections are joined together by an insulated partition to eliminate energy loss.



Technical Data

Technical Data Sheet

Voltage	230VAC	Single Phase / 30 Amps
Compressor FLA rating	14.6 - 16.2 amps	As per Copeland Performance Chart "A" attached
Condenser motor FLA rating	1.0 amps	
Evaporator motor FLA rating	.9 amps	
Heater amps	10 amps	
Heater delay-on-make	1 minute	solid-state device inside panel
CPR setting	Target range 25 - 30 Psi.	*During defrost amperage should not exceed 26.8 as per Copeland Electrical Data Chart "B" attached
Low pressure safety switch	Cut-In: 20 Psi. / Cut-Out: 5 Psi. Differential: 15 Psi.	
High pressure safety switch	400 Psi.	

condenser fan cycling switch	Cut-In: 250 Psi. / Cut-Out: 180 - 200 Psi. Differential: 50 - 70Psi.	Use higher differential to reduce short cycling
Electronic Expansion Valve	Factor superheat setting is 10°F	This setting should never be changed. If the Dixell which controls superheat should display a superheat reading that is more than 2 degees above or below this setting for a prolonged period of time, please refer to the troubleshooting guide to determine cause.
refrigerant type/amount	404A / 11 lbs.	
oil type	Polyolester Oil	
Sound readings	65 decibels @ 10' 60 decibels @ 20'	
weight	464 lbs.	



Controller – Parameters

Dual Map Position	Freezer	Cooler	
Minimum set-point	-10°F	+15°F	Dixell
Maximum set-point	+14°F	+50°F	Dixell
Interval between defrost cycles	6 hours	6 hours	Dixell
Time of first defrost cycle	6 hours after power is turned on/restored	6 hours after power is turned on/restored	Dixell
Defrost termination temperature	+55°F	+46°F	Dixell
Drain time	3 minutes	3 minutes	Dixell
Evaporator fan time delay	Evaporator coil @ 35°F	1 minutes	Dixell



Location of major components in the modular unit:

Air return: air return ventilation openings are located on the sides and the bottom of the evaporator. The dimensions of the openings are proportional to the air flow.

Fans: fans are located behind each coil. Fans are pushing the air through the evaporator coil and are pulling the air through the condenser coil, to perform an efficient heat transfer.

Defrost sequence:

Type of defrost: hot gas system.

Defrost cycles: the defrost cycles should last 3 – 10 minutes, depending on the frost accumulation and the evaporator coil temperature. The defrost cycle is initiated by the timer, which will automatically close and open solenoid valves in the unit and stop the evaporator fan motor. These valves will allow the hot thermal fluid to flow through the evaporator coil to perform the defrost. The temperature control will automatically terminate the defrost cycle and after a drip and time delay, will activate the evaporator fan motors.

Operational time: at maximum capacity the unit should operate effectively approximately 23 out of 24 hours per day. The one hour lost is for defrosting cycles.

Refrigerant:

404A used in the units is ozone friendly. We are aware of the environmental problems associated with the use of chlorofluorocarbonates.



Specifications:

COMPRESSOR

Model	Voltage	Quantity	HP	RLA	LRA
SB151	240/1/60	1	4	18	34.5

ELECTRIC MOTORS

Model	Voltage	Evaporator HP	RLA	Condenser HP	RLA	Speed
SB151	240/1/60	1/3	2.1	1/3	2.1	1075 RPM

REFRIGERATION UNIT

Model	HP	Range	Refrigerant	Width	Height
SB151	4	-10°F/+50°F	404A	40"	22"

REFRIGERATION UNIT– continued

Depth	RLA	LRA	Breaker
50"	26.8	34.5	30A



UNIT CAPACITY @ 110° F CONDENSING

Model	-10°F	-5°F	0°F	+5°F	+10°F
SB151	18,200	20,400	22,700	25,300	28,000

UNIT CAPACITY @ 110° F CONDENSING – continued

+15°F	+20°F	+25°F	+30°F	+35°F	+40°F
30,900	34,000	37,300	40,800	44,500	48,500

COMPRESSOR WINDING RESISTENCE

Model	VOLTS	PH	Max RLA	LRA	Winding Resistance		Run CAP P/N
COPELAND ZF13K4E-PFV	208/230	1	26.8	129	0.779 (S & C)	0.432 (C & R)	914-0037-38



Maintenance:

Monthly:

Verify sight glass for level of refrigerant while unit is in operation.

Check all fan motors for noises, vibrations, etc.

Check evaporator coil for frost accumulation. To correct, try a manual defrost.

Check evaporator and condenser coil for cleanliness.

Seasonal operation:

Clean all coils.

Verify fan blades for damages, cracks, or free rotation.

Check level of oil in the compressor.

Check level of refrigerant after a few complete cooling cycles.

Pre-cool room for 48 hours and check defrost.

Adjust thermostat to desired temperature.



Troubleshooting Guide

CONDITION	POSSIBLE CAUSE	REMEDY
1. UNIT DOES NOT RUN	External power source OFF	Turn on
	incorrect line voltage	check for 208-230 volts
No display on digital controller	on/off switch OFF or defective	Turn on or replace
	Circuit breaker tripped or OFF	reset or turn ON
Display is on and compressor is cool to the touch	Low pressure switch open	Check refrigerant sight glass for proper charge. Check for restricted liquid line filter. Check if CPR valve is holding back too much. Check if thermostatic head on TXV has lost its charge. If still unsure, recover refrigerant, pull vacuum and weigh in correct virgin charge.
	liquid line solenoid is closed	Check if there is power on coil, if yes then replace defective coil. if no power to coil then check thermostat setting or pump-down switch inside container.
Display is on and compressor is hot to the touch	High pressure switch open	check condenser fan operation, check condenser fan cycle control settings and make sure condenser is clean
	compressor winding failure	turn off power, allow to cool and check actual ohm readings against those listed in Copeland electrical handbook- If readings are off significantly, replace compressor and check superheat setting.



CONDITION	POSSIBLE CAUSE	REMEDY
	crankcase pressure regulating valve is not throttling enough and overloading the compressor, causing the compressor to go off on internal overload	wait for compressor to restart, allow to reach temperature and then check amperage readings while in defrost, making sure to adjust CPR closed enough to keep amperage below 26.8 as outlined in Copeland electrical manual.
	scroll has overheated and internal bypass port has opened	turn off power and check oil level in crankcase. Add oil if necessary to maintain 1/2 glass. Allow to cool for 2 or more hours and then retry. If compressor begins pumping, keep gauges and temperature probes connected to make sure that superheat is not excessive for any significant period of time.
Display is on and compressor is hot to the touch	one or more defective start components	Check relay and capacitors
2. UNIT REGULARLY RUNS WAY ABOVE SET-POINT AND/OR HAS DIFFICULTY DROPPING DOWN TO SET-POINT (note: set point lower range is limited to -10°F)		
	Excessive superheat setting	adjust TXV open....slowly!
	Condenser is dirty	turn off unit, clean condenser with hose and allow to dry before restarting
Refrigeration System	Evaporator is iced up	try manual defrost to clear the ice
	evaporator or condenser fan spinning slow or opposite direction	check run capacitor
	CPR valve is throttling too much	adjust CPR spring inward to allow more refrigerant flow making sure amps remain below 26.8 during defrost



CONDITION	POSSIBLE CAUSE	REMEDY
	low on refrigerant charge	BEFORE adding refrigerant check all the above first and when possible, recover refrigerant, pull vacuum and weigh in correct charge. Search for and repair all leaks.
	Evaporator heater contactor stuck	replace
	Hot gas solenoid valve leaking by	turn off power, recover refrigerant , remove coil, disassemble valve body and remove debris that is holding up the plunger
Load	Product being introduced into container at a core temperature greater than setpoint by more than 10F	introduce less load or reduce setpoint slightly (careful not to cause harm to product by freezing it)
3 UNIT REGULARLY DROPS WAY BELOW SET-POINT, WILL NOT HEAT OR HAS INSUFFICIENT HEATING (note: set-point upper range is limited to +50° F)		
	liquid line solenoid valve is leaking by	pump-down system, turn off power, remove coil, disassemble valve body and remove debris that is holding up the plunger
	defective heater	replace
	open circuit at limit switch	check for proper mounting location and/or replace if defective



	open circuit at heater lock-out relay	coil for heater contactor is wired in series to normally closed contacts on heater lock-out relay. Unless defective, heater can be energized so long as compressor remains off. Check for defective relay.
CONDITION	POSSIBLE CAUSE	REMEDY
	open circuit at solid state time-delay	allow 5 minutes for delay-on-make to occur, check and/or adjust setting, replace if remains open
	defective fuse	check for dead shorts in heater circuit and repair same prior to replacing fuse
	Heater contactor defective	Replace
	Evaporator fan motor spinning slowly or in opposite direction	check capacitor and replace if defective
	Temperature setting is too low	check setpoint on controller and allow 5 minutes for time-delay
	Loose terminal connections	Tighten
	Low line voltage	Check
4 UNIT WILL NOT DEFROST PROPERLY		
	Door was left open or large load was recently introduced	initiate manual defrost at the controller by pressing the water droplet symbol for 5 seconds
	evaporator probe fault	check for tight and proper installation of



		evaporator probe. Check controller display for proper temperature reading at this probe. If probe is reading several degrees higher than actual, defrost will terminate prematurely. Replace probe if defective.
CONDITION	POSSIBLE CAUSE	REMEDY
	large product loads are introduced regularly. Core temperature of product is greater than set-point by more than 10F.	although designed only as a holding box, you might want to try to reduce the interval time between defrosts from 6 hours down to 4 hours. To do so, you must contact SEA BOX and a technician will come out to reprogram the controller. Note: adding too many defrost cycles will eventually give diminishing returns as this system is designed with an 18- hour run-time to keep up with a normal load.
5 ABNORMAL NOISE OR VIBRATIONS		
Compressor	liquid slugging	Check TXV fuel-bulb for tight and proper installation. Check superheat and adjust TXV closed if necessary to maintain at least 10 F at the compressor. Do it in small steps and allow TXV to balance out after each adjustment.
	insufficient oil	add polyolester oil
Condenser or Evaporator Fan	Loose hub or worn motor bearings	Check
	Bent fan blade	
6 TEMPERATURE CONTROLLER		



MALFUNCTION		
6 TEMPERATURE CONTROLLER	sensor fault	check wiring, check installed location of 2 sensors, and/or replace defective sensor
	incorrect program	re-install chip and download program
	defective controller	Remedy
7. Excessive frost on compressor and superheat controller constantly displays a value substantially higher than 10°F	Liquid Slugging	<p>Temporarily disconnect wires for temperature probe at terminals 13 and 14 on the Dixell superheat controller and connect them to an ohm meter. Check temperature of suction line at the evaporator with your own temperature probe strapped tightly to the suction line. Now compare values from the chart provided to determine if probe is in calibration. If the temperature which corresponds to the resistance reading is higher than the actual reading you took by a significant amount, it is then determined to be faulty and it must be replaced as compressor damage will result.</p> <p>77°F - 10 kOhm 50°F - 19.9 kOhm 32°F - 32.7 kOhm 23°F - 42.3 kOhm 14°F - 55.3 kOhm 5°F - 72.9 kOhm -4°F - 97 kOhm</p> <p>If the temperature which corresponds to the resistance reading is in line with the</p>

		<p>actual reading then follow these steps to evaluate the pressure transducer accuracy. Temporarily disconnect wires for the pressure transducer at terminals 18 and 19 on the Dixell superheat controller. The PT5-18M has 4-20mA output. To check it, you can connect it as follow:</p> <p>There is linear dependence between pressure and current For 0 psig the current should be 4 mA For 130 psig the current should be 12 mA For 261 psig the current should be 20 mA</p> <p>Check pressure of the suction line with your own gauge and compare mA values from the chart provided below to determine if the transducer is in calibration. If the pressure which corresponds to the resistance reading is lower than the reading you took by a significant amount, it is then determined to be faulty and it must be replaced as compressor damage will result.</p>
--	--	---



Diagrams

The parts illustrations are on the following pages.

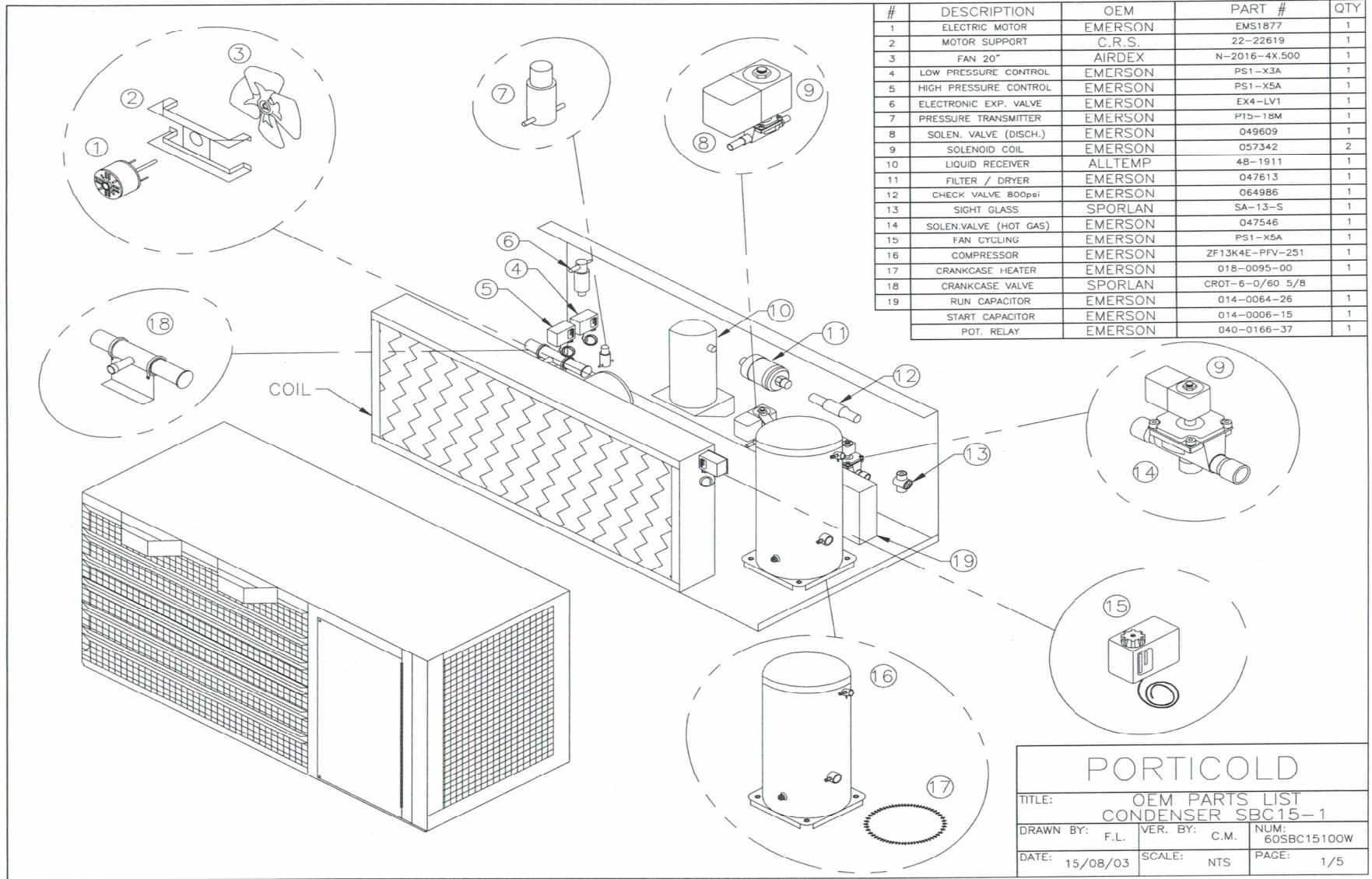

#	DESCRIPTION	OEM	PART #	QTY
1	ELECTRIC MOTOR	EMERSON	EMS1877	1
2	MOTOR SUPPORT	C.R.S.	22-22619	1
3	FAN 20"	AIRDEX	N-2016-4X.500	1
4	LOW PRESSURE CONTROL	EMERSON	PS1-X3A	1
5	HIGH PRESSURE CONTROL	EMERSON	PS1-X5A	1
6	ELECTRONIC EXP. VALVE	EMERSON	EX4-LV1	1
7	PRESSURE TRANSMITTER	EMERSON	PT5-18M	1
8	SOLENO. VALVE (DISCH.)	EMERSON	049609	1
9	SOLENOID COIL	EMERSON	057342	2
10	LIQUID RECEIVER	ALLTEMP	48-1911	1
11	FILTER / DRYER	EMERSON	047613	1
12	CHECK VALVE 800psi	EMERSON	064986	1
13	SIGHT GLASS	SPORLAN	SA-13-S	1
14	SOLENO VALVE (HOT GAS)	EMERSON	047546	1
15	FAN CYCLING	EMERSON	PS1-X5A	1
16	COMPRESSOR	EMERSON	ZF13K4E-PFV-251	1
17	CRANKCASE HEATER	EMERSON	018-0095-00	1
18	CRANKCASE VALVE	SPORLAN	CROT-6-0/60 5/8	1
19	RUN CAPACITOR	EMERSON	014-0064-26	1
	START CAPACITOR	EMERSON	014-0006-15	1
	POT. RELAY	EMERSON	040-0166-37	1

PORTICOLD			
TITLE: OEM PARTS LIST CONDENSER SBC15-1			
DRAWN BY:	F.L.	VER. BY:	C.M.
DATE:	15/08/03	SCALE:	NTS
NUM:	60SBC15100W	PAGE:	1/5

REFRIGERANT 404A

#	DESCRIPTION	QTY.	OEM	PART NUMBER
1	EVAPORATOR	1	C.R.S.	50SBC15-1W
2	ELECTRIC MOTOR	1	EMERSON	EMS1877
3	FAN	1	AIRDEX	2820895
4	TEMP.LIMIT SWITCH	1	ALLTEMP	LS2-120-2
5	MOTOR SUPPORT	1	C.R.S.	22-22619
6	RUN CAPACITOR	1	ALLTEMP	36-7.5J370
7	HEAT. ELEMENT 3000W	1	VOLTON	0.260" dia x 96"

SBC15-1 UNIT
208-230/1/60

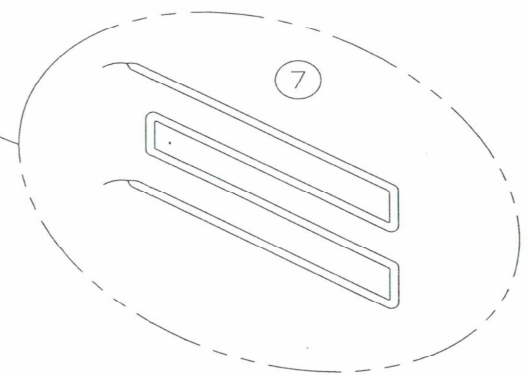
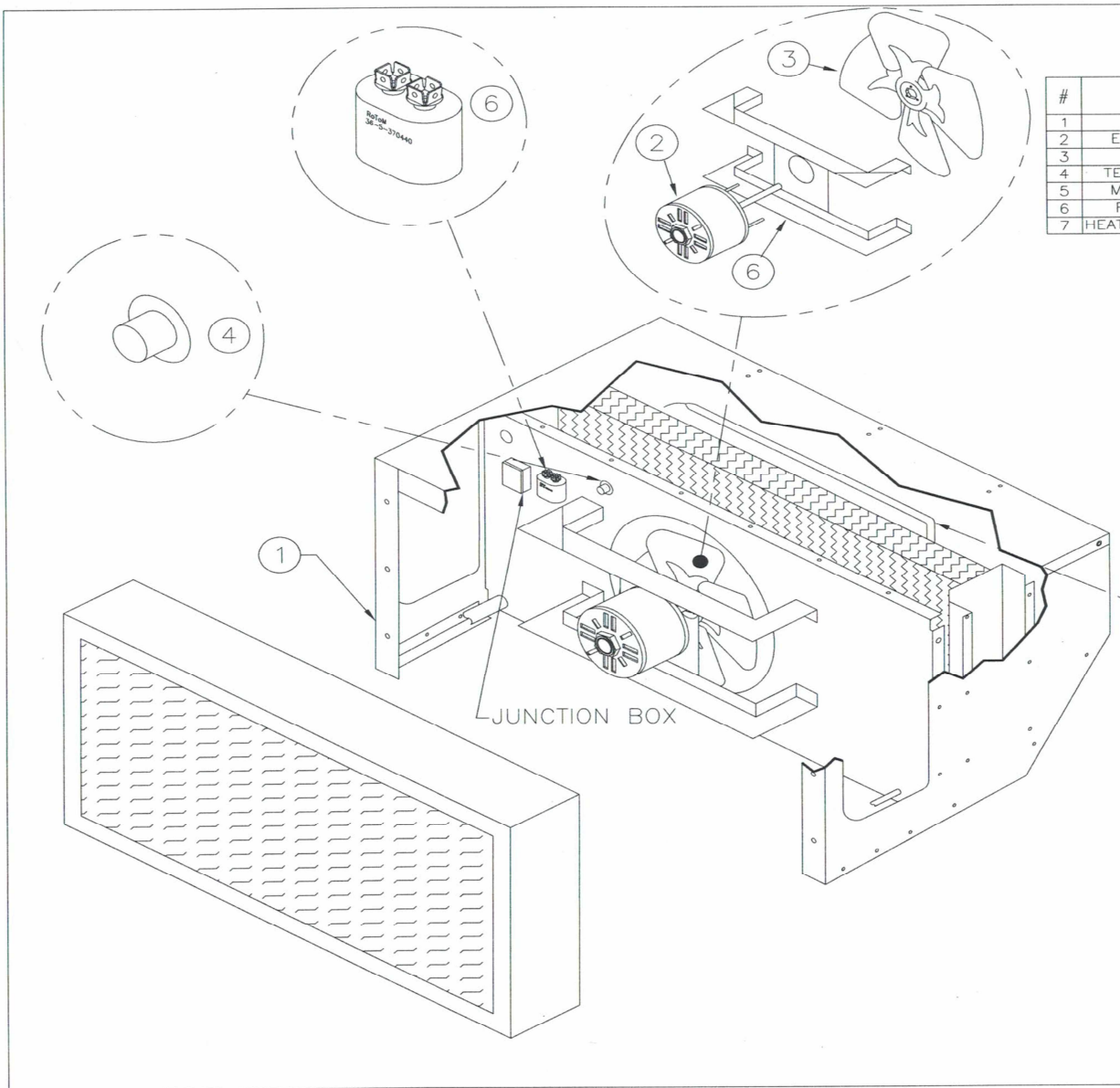

PORTICOLD			
TITLE: OEM PARTS LIST EVAPORATOR SBC15-1			
DRAWN BY: F.L.	VER. BY: C.M.	NUM: 50SBC15016W	
DATE: 15/08/03	SCALE: NTS	PAGE: 2/5	

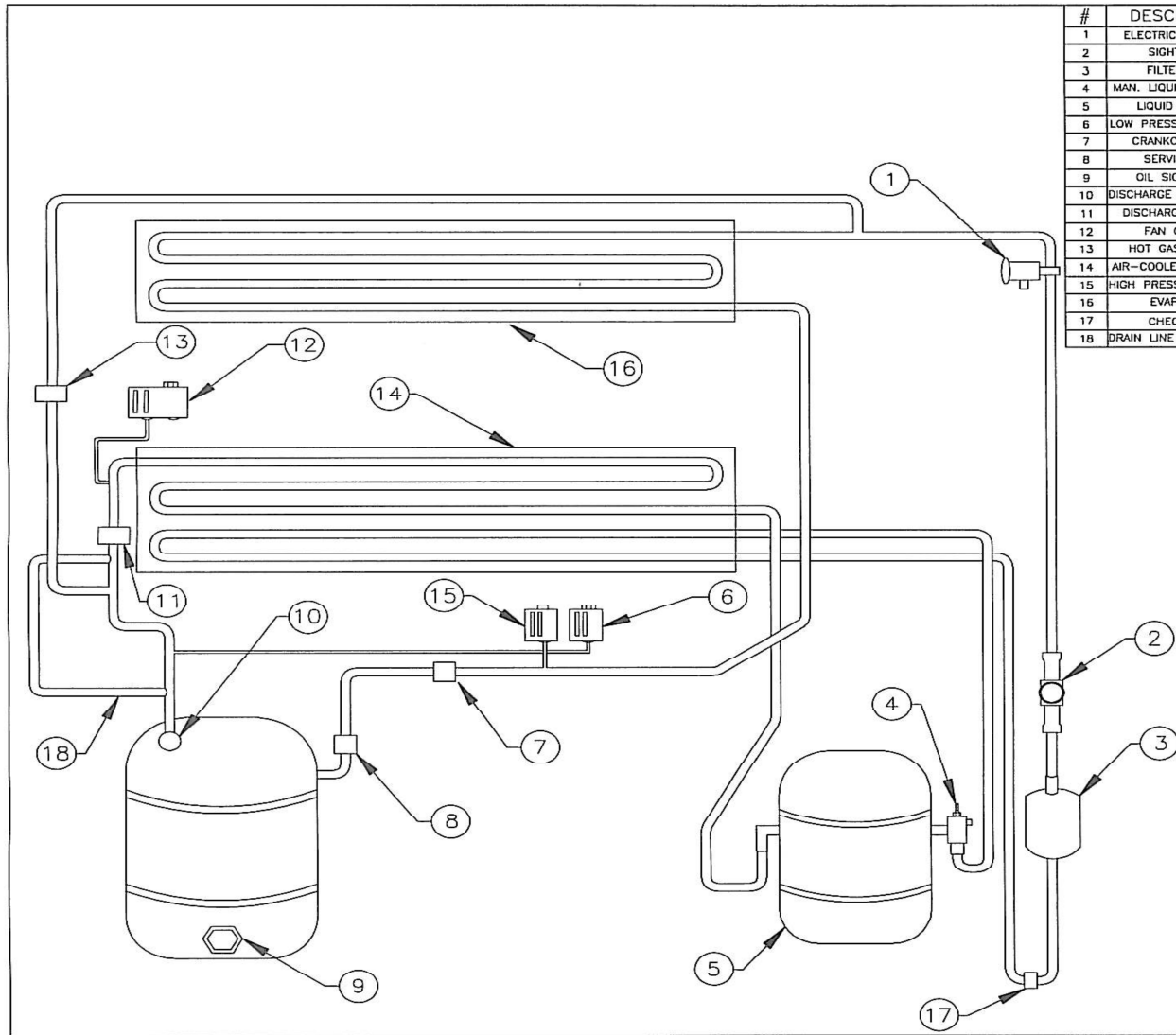

#	DESCRIPTION	OEM	PART #	QTY
1	ELECTRIC EXP. VALVE	EMERSON	EX4-LV1	1
2	SIGHT GLASS	SPORLAN	SA-135 3/8 OD	1
3	FILTER/DRIER	EMERSON	047613	1
4	MAN. LIQUID LINE VALVE	ALLTEMP	(LIQUID RECEIVER)	1
5	LIQUID RECEIVER	ALLTEMP	48-1911	1
6	LOW PRESSURE CONTROL	EMERSON	PS1-X3A	1
7	CRANKCASE VALVE	SPORLAN	CROT-6-0/60 5/8	1
8	SERVICE PORT	COPELAND	(COMPRESSOR)	1
9	OIL SIGHT GLASS	SPORLAN	SA-13-S	1
10	DISCHARGE SERVICE PORT	COPELAND	(COMPRESSOR)	1
11	DISCHARGE SOLENOID	EMERSON	063339	1
12	FAN CYCLING	EMERSON	PS1-X5A	1
13	HOT GAS SOLENOID	EMERSON	049609	1
14	AIR-COOLED CONDENSER	C.R.S.	60SBC15-1	1
15	HIGH PRESSURE CONTROL	EMERSON	PS1-X5A	1
16	EVAPORATOR	C.R.S.	50SBC15-1	1
17	CHECK VALVE	EMERSON	064986	1
18	DRAIN LINE HOT GAS loop	C.R.S.	-----	1

PORTICOLD		
TITLE: REFRIGERATION CIRCUIT SBC15-1		
DRAWN BY: F.L.	VER. BY: C.M.	NUM: 80SBC15016W
DATE: 15/08/03	SCALE: NTS	PAGE: 3/5

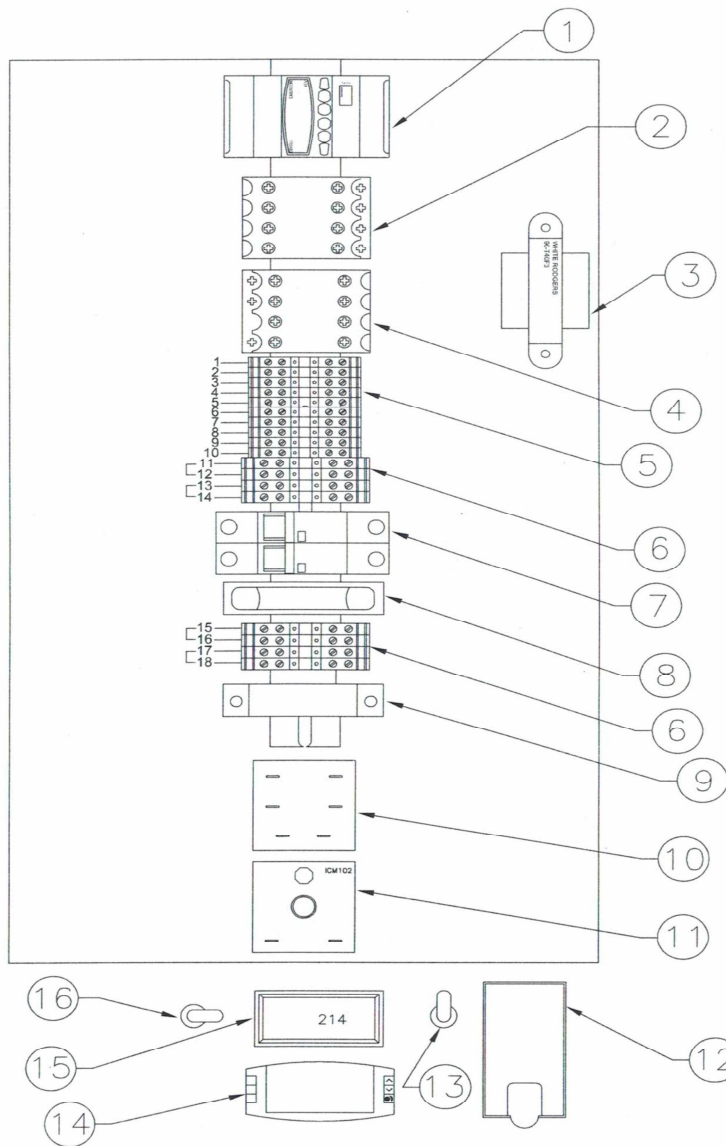

#	OEM	DESCRIPTIONS	PART #	QTY
1	EMERSON	XEV SUPERHEAT CONTROL	318-5001	1
2	TECHSPAN	COMPRES. CONTACTOR	TCI-D3201-U7	1
*3	EMERSON	24V TRANSFORMER	90-T40F3	1
4	TECHSPAN	HEATER CONTACTOR	TCI-D1801-U7	1
5	TECHSPAN	TERMINAL STRIP	CTS2.5U-N	10
6	TECHSPAN	TERMINAL STRIP	CMC2-2	8
7	FUSETEK	CIRCUIT BREAKER	JTECUL2C08	
8	GUILLEVIN	SPARE FUSE HOLDER	BM603150	1
9	FUSETEK	CIRCUIT BREAKER(N/U)	LPSC001	1
10	HONEYWELL	RELAY	R4222D1021	1
11	ICM CONTROLS	FAN TIME DELAY	24-ICM102	1
12	SCHNEIDER	30A. BREAKER	QOU230	1
13	DEL CITY	DPST SWITCH	730013	1
14	WEISS INSTRUMENTS	DIXELL CONTROLLER	XR70CX	1
15	NEWARK	VOLTAGE METER	DMS-20PC-1LMBC	1
16	DEL CITY	SPST SWITCH	73020	1

LEFT : RIGHT

- 1 - S (black) : S (white)
- 2 - G (brown) : G (brown)
- 3 - A (orange) : A (orange)
- 4 -
- 5 - 23 (black) : 23 (purple)
- 6 - 17 (black) : 17 (brown)
- 7 - 14 (black) : 14 (blue)
- 8 - L1A (black) : L1A (orange)
- 9 - L2A (black) : L2A (pink)
- 10 - L2A (black) : L2A (blue)
- 11 - 5 (black) : -
- 12 - 5 (black) : L2 (black)
- 13 - L1 (red) : L1 (red)
L1 (black) : L1 (yellow)
- 14 - L1 (black) : L1 (red)
- : L1 (black)

LEFT : RIGHT

- 15 - L2 (black) : -
L2 (black) : -
- 16 - L2 (black) : -
L2 (black) : L2 (black)
- 17 - L1 (red) : -
L1 (red) : L2 (red)
- 18 - L1 (black) : -
L1 (red) : L1 (white)

PORTICOLD

TITLE: OEM PARTS LIST ELECT.BOX SBC15-1			
DRAWN BY:	F.L.	VER. BY:	C.M.
		NUM:	37SBC15016W
DATE:	15/08/03	SCALE:	NTS
		PAGE:	4/5

Electrical Diagrams

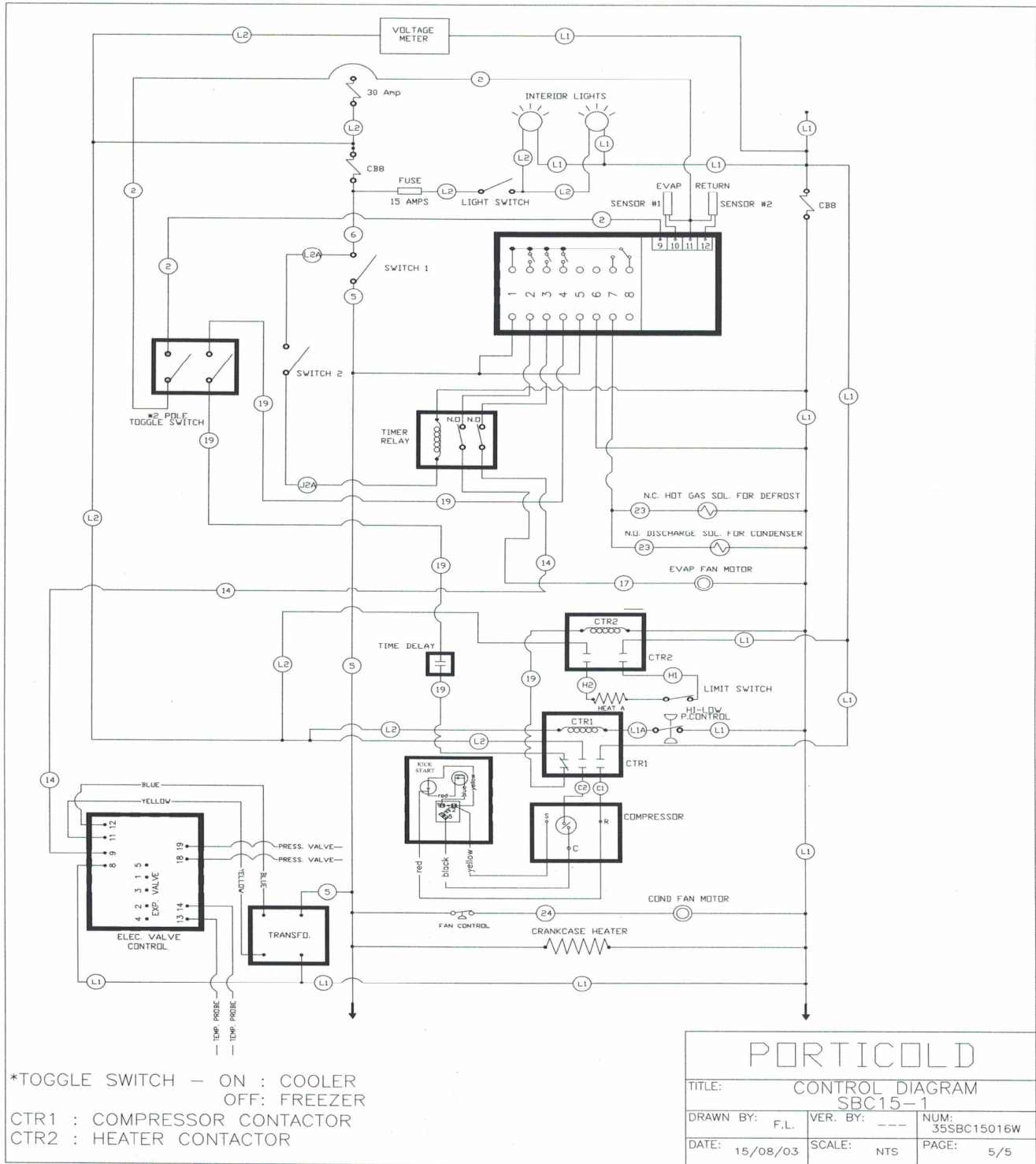

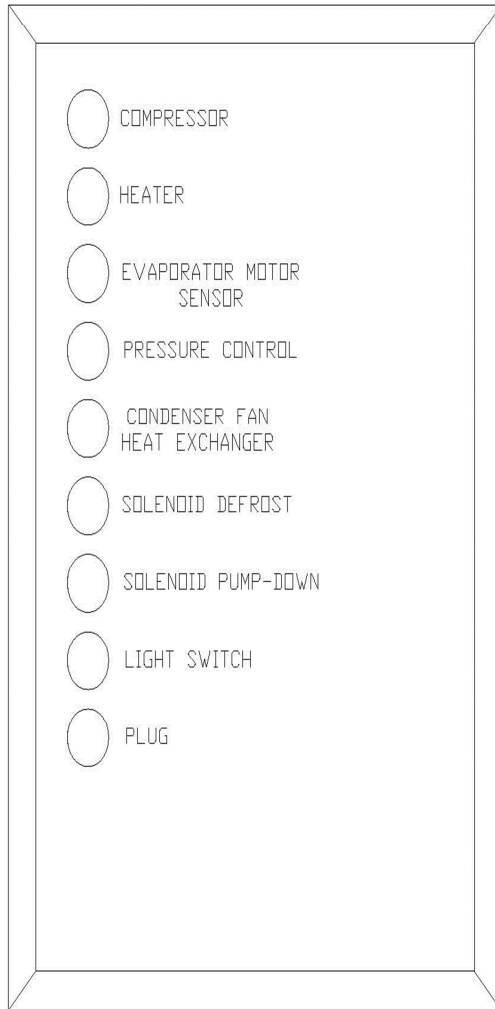

PORTICOLD		
TITLE: SBC15-1		
CABLE LOCATIONS		
DRAWN BY:	F.L.	VER. BY: ---
		NUM: ---
DATE:	16/07/12	SCALE: NTS
		PAGE: 6/6

Quick Reference Wiring - 1 Phase Buck and Boost Transformer



REQUIRED VOLTAGE: 230 VAC 1 Phase 60 Amps

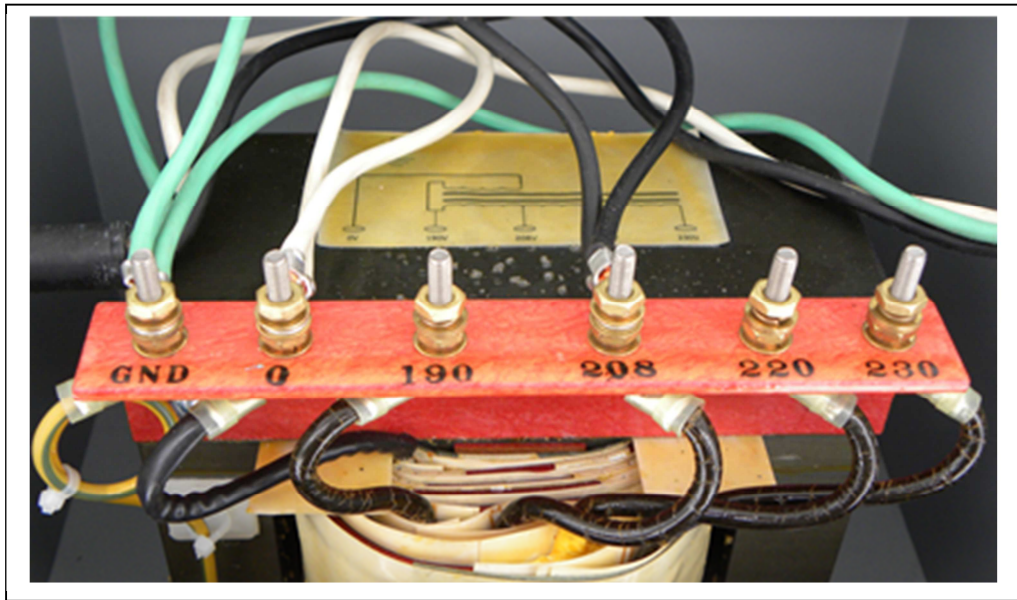

- Take a voltage reading at the main power source.
- If the voltage is less than 230 volts, utilize the buck and boost transformer.
- Open the hinged cover on the transformer.
- Measure with a volt meter, set to read AC volts on the 600 volt scale, between the 0 lug on the transformer wire and the other terminals.
- Note which terminal is at 230 volts. **TURN OFF POWER AT THE SOURCE**
- Connect the black wire coming from the power source to the terminal measuring closest to the incoming voltage. Move the black wire that goes to the refrigeration unit to the terminal that measured closest to or at 230 VAC.
- **DO NOT ALLOW VOLTAGE TO EXCEED 240VAC**
- Check that all nuts are tight and secure. Loose connections can cause a variety of problems that at first may not seem power related.
- Take voltage readings to confirm that the voltage is now at the desired level.

REFERENCE PAGE 6 through 8 FOR MORE DETAILS



Domestic Reefers Series

Unit number Start	Unit Number Stop	Date	Revision Level Manual
585000	585019	10/2010	00
585020	585039	10/2011	01
585040	585069	08/2012	02
585070	585089	10/2013	03
585090	585119	09/2014	04
585120	585129	09/2015	05